

TOMAHAWK

TRT46V
RIDE ON POWER TROWEL

Operation Manual



TABLE OF CONTENTS

1. Safety Information	4
2. General Information	7
3. Technical Data	9
4. Quick Start Guide	10
5. Controls and Components	11
6. Engine	13
7. Pre-Inspection	15
8. Initial Start Up	17
9. Starting the Engine	18
10. Stopping the Engine	19
11. Operation	22
12. Accessory Options	23
13. Maintenance	24
14. Training Checklist	28
15. Features and Troubleshoot	29
16. Catalog and Coupon	42

Register Your Equipment

Thank you for purchasing TOMAHAWK equipment! Your product is covered by the TOMAHAWK Warranty policy, but in order to activate your warranty, we need you to register your product. In addition to activating your equipment warranty, product registration will grant you access to important product updates, streamlined customer service and more.

INCLUDED WITH YOUR REGISTRATION

- ✓ Equipment Warranty Activation
- ✓ Product Updates
- ✓ Streamlined Customer Service
- ✓ Exclusive Discounts and Sales

STEPS TO REGISTER YOUR EQUIPMENT

1. Visit www.tomahawk-power.com
2. Choose “Product Registration” at the bottom of the page
3. Enter your equipment’s serial number to get started
4. Provide all required information
5. Submit Registration

Equipment Resources

Tomahawk Customer Service doesn’t stop at checkout. We understand to keep a job-site running smoothly - the proper equipment, spare parts, instruction manuals, and more are needed at the drop of a hat. Visit www.tomahawk-power.com to gain access to the incredible resources below.

How To Video Library

More of a visual person? Visit our Video Library for equipment assembly instructions, troubleshooting tips, and more!

Found on each product listing or the Service Videos Page

Manual and Assembly Guide Library

Visit our Manual Library if you are looking for a lost operations manual or a particular spare part?

Found on each product listing or the Tomahawk Manuals Page

Service Requests

In need of a quick fix or a service center referral? Submit a Service Request and a Tomahawk Technician will respond shortly to get you the help you need.

Choose “Service Request” at the bottom of www.tomahawk-power.com



This manual provides information and procedures to safely operate and maintain this equipment. For your own safety and protection from injury, carefully read, understand and observe the safety instructions described in this manual.

Keep this manual or a copy of it with the equipment. If you lose this manual or need an additional copy, please contact Tomahawk Power LLC or visit www.tomahawk-power.com. This equipment is built with user safety in mind; however, it can present hazards if improperly operated and serviced. Follow operating instructions carefully. If you have questions about operating or servicing this equipment, contact Tomahawk Power.

The information contained in this manual is based on equipment's production at the time of publication. Tomahawk Power reserves the right to change any portion of this information without notice.

No part of this publication may be reproduced in any form or by any means, electronic or mechanical, including photocopying, without express written permission from Tomahawk Power.

Any type of reproduction or distribution not authorized by Tomahawk Power represents an infringement of valid copyrights and will be prosecuted. We expressly reserve the right to make technical modifications, even without due notice, which aim at improving our machines or their safety standards.

1. SAFETY INFORMATION

This manual contains DANGER, WARNING, CAUTION, and NOTE callouts which must be followed to reduce the possibility of personal injury, damage to the equipment, or imM proper service.



This is the safety alert symbol. It is used to alert you to potential personal injury hazards. Obey all safety messages that follow this symbol to avoid possible injury or death.



DANGER indicates an imminently hazardous situation which, if not avoided, will result in death or serious injury.



WARNING indicates a potentially hazardous situation which, if not avoided, could result in death or serious injury.



CAUTION indicates a potentially hazardous situation which, if not avoided, may result in minor or moderate injury.

CAUTION: Used without the safety alert symbol, **CAUTION** indicates a potentially hazardous situation which, if not avoided, may result in property damage.

1.1 Laws Pertaining to Spark Arresters

Notice: State Health Safety Codes and Public Resources Codes specify that in certain locations spark arresters be used on internal combustion engines that use hydrocarbon fuels. A spark arrester is a device designed to prevent accidental discharge of sparks or flames from the engine exhaust. Spark arresters are qualified and rated by the United States Forest Service for this purpose.

In order to comply with local laws regarding spark arresters, consult the engine distributor or the local Health and Safety Administrator.

1.2 Operating Safety



Familiarity and proper training are required for the safe operation of equipment! Equipment operated improperly or by untrained personnel can be dangerous! Read the operating instructions contained in both this manual and the engine manual and familiarize yourself with the location and proper use of all controls. Inexperienced operators should receive instruction from someone familiar with the equipment before being allowed to operate the machine.

1.2.1 NEVER allow anyone to operate this equipment without proper training. People operating this equipment must be familiar with the risks and hazards associated with it.

1.2.2 NEVER touch the engine or muffler while the engine is on or immediately after it has been turned off. These areas get hot and may cause burns.

1.2.3 NEVER use accessories or attachments that are not recommended by Tomahawk Power. Damage to equipment and injury to the user may result.

1.2.4 NEVER leave machine running unattended.

1.2.5 ALWAYS be sure operator is familiar with proper safety precautions and operation techniques before using machine.

1.2.6 ALWAYS wear ANSI Z87.1-approved safety goggles or safety glasses with side shields, or when needed, a face shield. Use a dust mask in dusty work conditions. Also use non-skid safety shoes, hardhat, gloves, dust collection systems, and hearing protection when appropriate. This applies to all persons in the work area.

1.2.7 ALWAYS close fuel valve on engines equipped with one when machine is not being operated.

1.2.8 ALWAYS store equipment properly when it is not being used. Equipment should be stored in a clean, dry location out of the reach of children.

1.2.9 ALWAYS operate machine with all safety devices and guards in place and in working order. DO NOT modify or remove safety devices. DO NOT operate machine if any safety devices or guards are missing or inoperative.

1.2.10 ALWAYS read, understand, and follow procedures in Operator's Manual before attempting to operate equipment.

1.3 Safety while using Combustion Engines



DANGER

Internal combustion engines present special hazards during operation and fueling! Read and follow warning instructions in engine owner's manual and safety guidelines below. Failure to follow warnings and DANGER safety guidelines could result in severe injury or death.

1.3.1 DO NOT run machine indoors or in an enclosed area such as a deep trenches unless there is adequate ventilation, through such items as exhaust fans or hoses are provided. Gasoline exhaust from the engine contains poisonous carbon monoxide gas; exposure to carbon monoxide can cause loss of consciousness and may lead to death.

1.3.2 DO NOT smoke while operating machine.

1.3.3 DO NOT smoke when refueling engine.

1.3.4 DO NOT refuel hot or running engine.

1.3.5 DO NOT refuel engine near open flame.

1.3.6 DO NOT spill fuel when refueling engine.

1.3.7 DO NOT run engine near open flames.

1.3.8 ALWAYS refill fuel tank in well-ventilated area.

1.3.9 ALWAYS replace fuel tank cap after refueling.

1.3.10 ALWAYS check fuel lines and fuel tank for leaks and cracks before starting engine.

1.3.11 DO NOT run machine if fuel leaks are present or fuel lines are loose.

1.4 Service Safety



WARNING

Poorly maintained equipment can become a safety hazard! In order for the equipment to operate safely and properly over a long period of time, periodic maintenance and occasional repairs are necessary.

1.4.1 DO NOT attempt to clean or service machine while it is running. Rotating parts can cause severe injury.

1.4.2 DO NOT crank a flooded engine with the spark plug removed on gasoline-powered engines. Fuel trapped in the cylinder will squirt out the spark plug opening.

1.4.3 DO NOT test for spark on gasoline-powered engines, if engine is flooded or the smell of gasoline is present. A stray spark could ignite fumes.

1.4.4 DO NOT use gasoline or other types of fuels or flammable solvents to clean parts, especially in enclosed areas. Fumes from fuels and solvents can become explosive.

1.4.5 ALWAYS keep area around muffler free of debris such as leaves, paper, cartons, etc. A hot muffler could ignite them, starting a fire.

1.4.6 ALWAYS replace worn or damaged components with spare parts designed and recommended by Tomahawk Power.

1.4.7 ALWAYS disconnect spark plug on machines equipped with gasoline engines, before servicing, to avoid accidental start-up.

1.4.8 ALWAYS keep machine clean and labels legible. Replace all missing and hard-to-read labels. Labels provide important operating instructions and warn of dangers and hazards.

1.4.9 ALWAYS check for damaged parts before each use. Carefully check that the trowel will operate properly and perform its intended function. Replace damaged or worn parts immediately. Never operate the trowel with a damaged part.

1.4.10 ALWAYS inspect the screed prior to placing in storage and before re-use. Store the trowel in a dry, secure place out of the reach of children when not in use.

1.4.11 ALWAYS use only accessories that are recommended by the manufacturer for use with the trowel. Accessories that may be suitable for one trowel may create a risk of injury when used with the screed equipment.

1.4.12 ALWAYS keep blades clean when not in use and guards in place and in working order.

2. GENERAL INFORMATION

2.1 Intended Use

Leave laborious hand-finishing tasks in the past with the Tomahawk Power Trowels! Densify concrete floors with ease for your ideal finishing results on projects including driveways, basements, and commercial/industrial jobs.

2.2 Trowel Familiarization

Tomahawk Power Trowels are designed for the floating and finishing of concrete slabs. Analyze your trowel and take notice of each component: the engine, blades, quick pitch control, air cleaner, centrifugal stop switch, clutch and pulley system. Be sure that there is always oil in the engine.

2.3 Safety

Before using your power trowel, read all of the safety instructions carefully. Safety instructions are available throughout this manual and on the equipment. Safety information should remain in good, readable condition. Operators must be well trained on the operations and maintenance of the trowel.

Before starting, test the trowel on a flat, watered down section of finished concrete. Test on a section that is free of any debris and other objects.

The trial test run will increase operator confidence, while helping familiarize yourself with the trowel's controls. In addition, this will help operators understand how the power trowel functions under real conditions.

2.4 Engine

Refer to the engine owner's manual for instructions regarding the operation and maintenance of your engine. The engine manual is included with your trowel. For further assistance or to receive a new manual, contact Tomahawk Power customer service at (866) 577-4476 or refer to the Manuals Page on the Tomahawk Power website.

2.5 Drive System

The power is transferred from the engine to the gearbox input shaft via a V-belt pulley drive system. The pulley engages using either a centrifugal or manual clutch. Refer to the Parts section of this manual for more information.

2.6 Gearbox

The gearbox is located beneath the engine and transfers power to the rotor or spiderbox assembly. The gearbox controls the rotational speed of the trowel and is equipped with two shafts (input and output).

2.7 Spiderbox

The vertical output shaft of the gearbox connects to a cast hub called the spiderbox. The spiderbox has 4 arms that extend outward that are used for attachment of blades or other accessories. Remember: when the gearbox output shaft rotates, so does the spiderbox assembly.

2.8 Guard Ring

Some units are equipped with a special rotating guard ring. It is designed to allow the operator to run the machine alongside walls, pipes, and obstructions without marring the surface.

2.9 Blades

The blades of the trowel are used to finish the concrete as they rotate around your given surface. This trowel includes 4 combination blades (8 in./203mm wide) per rotor. They are equally spaced in a radial pattern and attached to the vertical rotating shaft by means of the spider assembly.

2.10 Centrifugal Clutch

In the event of a trowel runaway condition (the operator releases the handle), the centrifugal clutch will stop the engine and bring the trowel to a complete stop.

2.11 Training

For proper training education, refer to the “TRAINING CHECKLIST” section located in the back of this manual. This checklist contains an outline for an experienced operators to provide training to a new operator.

2.12 Operation

To utilize your Ride-On Trowel to its fullest capacity, the machine should be driven in the direction that the operator is facing. This will finish the widest possible area, while giving the operator an excellent view of the slab surface about to be troweled. When the machine reaches the end of the slab, make a 180°U-turn, and repeat the straight line of direction to the other end of the slab.

3. TECHNICAL DATA

Model	TRT46V
Engine type	Vanguard
Power	35HP/993cc
Operating weight	1349lb
Blade speed	75-150
Working Dia.	2320
Blade pitch (range)	0-15
Overlapping	Non-overlapping
Gearbox Lubrication	Glygoyle / 1300
Fuel Tank Capacity	5.2 gal
Water Tank Capacity	2.6 gallons

4. QUICK ASSEMBLY GUIDE

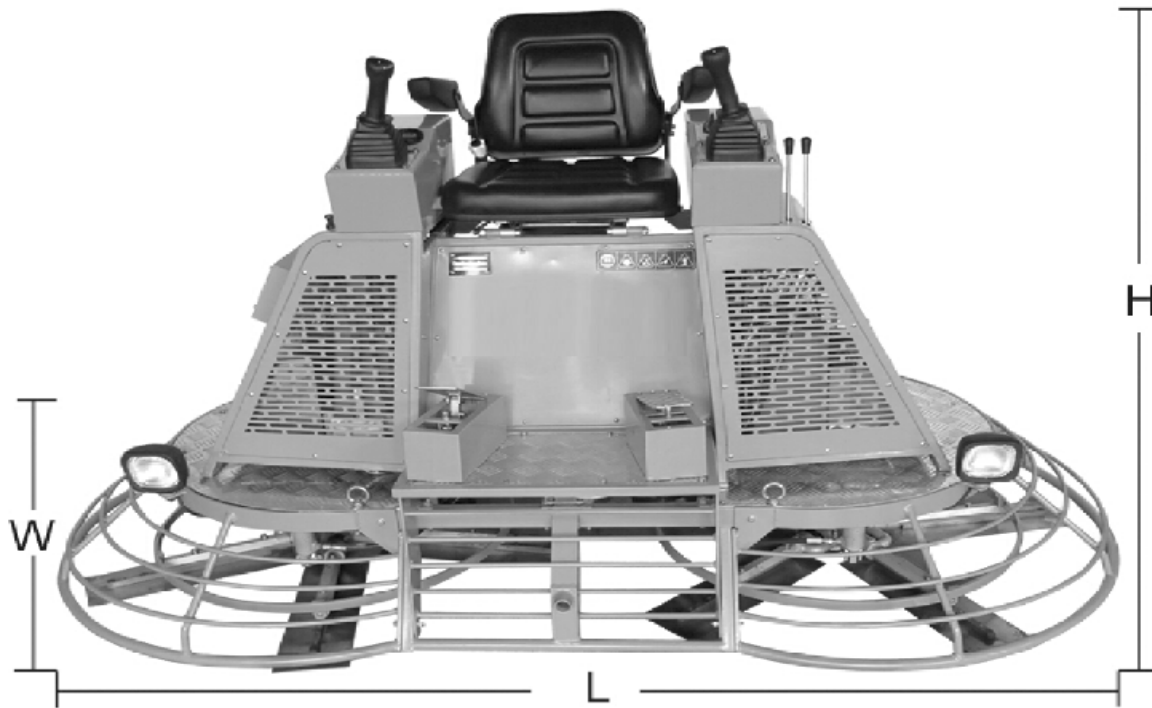

Working Size (L x W x H): 96.9" x 47.6" x 53.9"

Sound Specification

The required sound specification:

The sound pressure level at operator's location (LpA): 91 dB(A)

The guaranteed sound power level (LWA): 110 dB(A)

These sound values were determined according to ISO 3744 for the sound power level (LWA) and ISO 11204 for the sound pressure level (LpA) at the operator's location.

Vibration Specification

The weighted effective acceleration value, determined according to ISO 2361-1 and ISO 5349, is:

for whole body: 1.90 m/s²

for hand arm: 3.91 m/s²

1.5 Safety and Operating Labels

Ref.	Label	Meaning
A		<p>DANGER! Engines emit carbon monoxide; operate only in well-ventilated area. Read the Operation Manual for machine information. No sparks, flames, or burning objects near the machine. Shut off the engine before refueling. Use only clean, filtered unleaded gasoline.</p>
B		<p>WARNING! Cutting hazard. Always replace blade guard!</p>
C		<p>Steering control. Refer to section Steering.</p>
D		<p>WARNING! Always wear hearing and eye protection when operating this machine.</p>
Ref.	Label	Meaning
E		<p>Water tank fill. Use only clean water or water-based retardants.</p>
F		<p>CAUTION! Check the fuel. Use only clean, filtered gasoline fuel.</p>
G		<p>WARNING! Hand injury if caught in moving belt. Always replace belt guard.</p>

5.5 Engine

Tomahawk Power Trowels use Honda and Kohler engines and are backed by a 3-year engine warranty for reliable service.

5.6 Blade Pitch Control

Adjust the trowel's steel blades from 0-28 degrees to achieve a matte, light gloss, or gleaming finish.

5.7 Guard Ring

NEVER put hands and feet inside the guard ring.

5.8 Trowel Arm

Provides attachment points for the blades. If the blades show uneven wear patterns or if blades wear out faster than others, the trowel arm may need to be replaced.

5.9 Blades

This trowel is equipped with 4 combo hardened, steel blades designed for both float and finish operations. These blades are interchangeable with most manufacturers.

5.10 V-Belt Cover

Remove this cover to gain access to the V-Belt. NEVER operate the trowel with this cover removed.

5.11 Tee Handle

Loosen to fold handle.

5.2 Additional Components

5.2.3 Auxiliary Lifting Tube

Use this tube to lift the trowel onto a slab. Tube is to be inserted into the socket located in front of the gearbox. Available with select units.

6. ENGINE

6.1 Servicing

The engine must be checked for proper lubrication and filled with fuel prior to operation. Refer to the manufacturer's engine manual for instructions & details of operation and servicing. If a problem should arise, or if you have any questions about your engine, consult an authorized Honda or Kohler servicing dealer.

The Importance Of Maintenance

Good maintenance is essential for safe, economical and trouble-free operation. It will also help reduce pollution.



WARNING:

Improper maintenance, or failure to correct a problem before operation, can cause a malfunction in which you can be seriously hurt or killed. Always follow the inspection and maintenance recommendations and schedules in this owner's manual.

To help you properly care for your engine, the following pages include a maintenance schedule, routine inspection procedures, and simple maintenance procedures using basic hand tools. Other service tasks that are more difficult, or require special tools, are best handled by professionals and are normally performed by a Honda or Kohler technician or other qualified mechanic.

The maintenance schedule applies to normal operating conditions. If you operate your engine under severe conditions, such as sustained high-load or high-temperature operation, or use in unusually wet or dusty conditions, consult your servicing dealer for recommendations applicable to your individual needs and use.

Maintenance, replacement, or repair of the emission control devices and systems may be performed by any engine repair establishment or individual, using parts that are “certified” to EPA standards.

6.2 Maintenance Safety

Some of the most important safety precautions follow. However, we cannot warn you of every conceivable hazard that can arise in performing maintenance. Only you can decide whether or not you should perform a given task.



WARNING:

Failure to properly follow maintenance instructions and precautions can cause you to be seriously hurt or killed. Always follow the procedures and precautions in this owner's manual.



CAUTION:

NEVER attempt to lift the trowel by yourself.
ALWAYS get assistance from another person to help lift the trowel.

6.2 Maintenance Safety Continued

6.2.1 Fuel Filler Cap

Remove this cap to add unleaded gasoline to the fuel tank. Make sure the fuel filler cap is tightened securely. DO NOT overfill.

6.2.2 Throttle Lever

The throttle lever is used to adjust engine RPM speed (lever advanced forward SLOW, lever back toward operator FAST).

6.2.3 Engine ON/OFF Switch

ON position permits engine starting, OFF position stops engine operations.

6.2.4 Recoil Starter (Pull Rope)

Manual-starting method. Pull the starter grip until resistance is felt, then pull briskly and smoothly.

6.2.5 Fuel Valve Level

OPEN to let fuel flow, CLOSE to stop the flow of fuel.

6.2.6 Choke Lever

Used in the starting of a cold engine or in cold weather conditions, the choke enriches the fuel mixture.

6.2.7 Air Cleaner

The air cleaner prevents dirt and other debris from entering the fuel system. To access the filter element, remove the wing-nut on top of the air filter canister.

NOTE:

Do not operate the engine without an air filter, with a damaged air filter, or a filter in need of replacement. This will allow dirt to enter the engine and cause rapid engine wear.

6.2.8 Spark Plug

The spark plug provides a spark to the ignition system. Clean the spark plug once a week. Set the spark plug gap to 0.6 - 0.7mm (0.028 - 0.031in).

6.2.9 Muffler

The muffler is used to reduce noise and emissions from the engine.



WARNING:

Engine components can generate extreme heat. To prevent burns, DO NOT touch these areas while the engine is running or immediately after operating. NEVER operate the engine with the muffler removed.

6.2 Maintenance Safety Continued

6.2.10 Fuel Tank

The fuel tank holds unleaded gasoline. For more information, refer to the engine owner's manual.

7. PRE-INSPECTION

NEVER operate the power trowel in a confined area or enclosed structure that does not provide ample free flow of air.

ALWAYS wear approved eyewear and hearing protection before operating the trowel.

NEVER place hands or feet inside the guard rings while the engine is running.

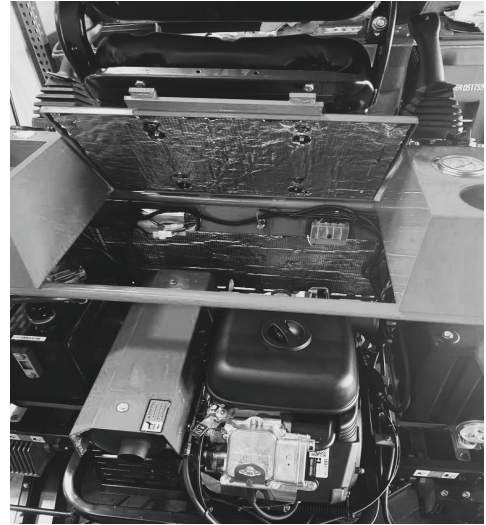

ALWAYS shut the engine down before performing any kind of maintenance on the trowel.

It is recommended that the trowel's kill switch be used to stop the engine after every use. Doing this will verify that the switch is working properly and presents no danger to the operator. (Figure 1 for reference)

7.1 Before Starting

7.1.1 Read the safety instructions at the beginning of this manual.

7.1.2 Clean the power trowel by removing dirt and dust, particularly in the engine cooling air inlet, carburetor, and air cleaner.

7.1.3 Check the air filter for dirt and dust. If the air filter is dirty, replace it with a new one as required.

7.1.4 Check the carburetor for external dirt and dust. Clean it with dry compressed air.

7.1.5 Check fastening nuts and bolts for tightness.

7.2 Engine Oil Check

7.2.1 To check the engine oil level, place the power trowel on a secure level ground with the engine stopped.

7.2.2 Remove the filler dipstick from the engine oil filler hole (Figure 2) and wipe it clean.

7.2.3 Insert and remove the dipstick without screwing it into the filler neck. Check the oil level shown on the dipstick.

7.2.4 If the oil level is low (Figure 3), fill to the edge of the oil filler hole with the recommended with SAE10W-30 4 stroke oil. Maximum oil capacity is 400 cc.

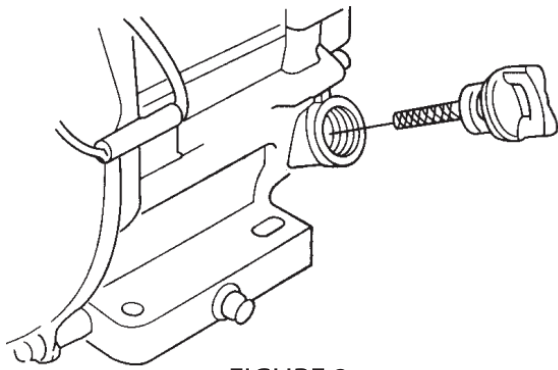

FIGURE 2

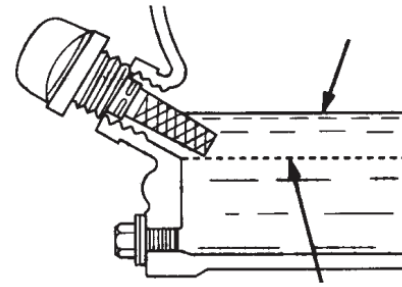

FIGURE 3

7.3 Fuel Check

Engine fuels are highly flammable and can be dangerous if mishandled. **DO NOT** smoke while refueling. **DO NOT** attempt to refuel the trowel if the engine is hot or running.

7.3.1 Remove the gasoline cap that is located on top of the fuel tank.

7.3.2 Visually inspect to see if fuel level is low. If fuel is low, replenish with 89 Octane gasoline.

7.3.3 When refueling, be sure to use a strainer for filtration. **DO NOT** top-off the fuel. Wipe up any spilled fuel.

7.4 Gearbox Oil

Oil type: Mobil Gear Oil 220

Amount: 43 Fluid Ounces

7.4.1 Determine if the gearbox oil is low by removing the oil plug located on the side of the gearbox. This plug will be marked by the "check" decal. See Figure 4. The correct level of the lubrication oil should be to the bottom of the fill plug.

7.4.2 If lubrication oil begins to seep out as the drain plug is being removed, then it can be assumed that the gearbox has a sufficient amount of oil.

7.4.3 If lubrication oil does not seep out as the drain plug is being removed, fill with type ISO 680 gearbox lubricant oil until the oil filler hole overflows.

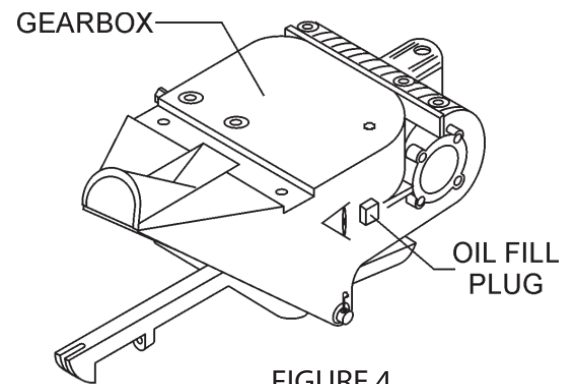

FIGURE 4

7.5 V-Belt Check

A worn or damaged V-belt can adversely affect the performance of your power trowel. If a V-belt is defective or worn out, simply replace the V-belt as outlined in the maintenance section of this manual.

7.6 Blade Check

Before starting, check for worn or damaged blades. If one blade is worn out while the others look new, this could be because of a blade pitch problem. Refer to the maintenance section of this manual for instructions on the blade pitch adjustment procedure. Replace any worn out blades.

7.7 SAFETY KILL SWITCHES

This power trowel has been equipped with a safety kill switch. Safety kill switches should be tested every time the engine is started. (Figure 1)

NOTE

NEVER! disable or disconnect the kill switch. It is provided for operator safety. Injury may result if it is disabled, disconnected, or improperly maintained.

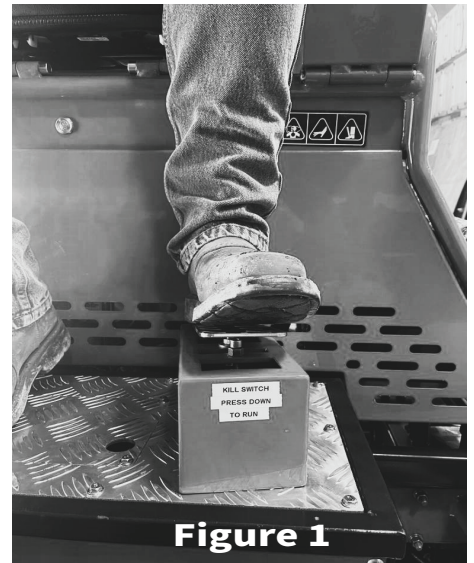

Figure 1

7.8 HANDLE PRESS KILL SWITCH

Located on the main handle tube is a red switch (Figure 5). The switching mechanism of this switch should operate freely and should always be kept in this condition. With the switch in the OFF position, the engine should not start or run. The purpose of this switch is to stop the engine in a runaway situation, (i.e.-the operator releasing the handle during operation).

DO NOT let the machine sit unused with the engine at high speed for an extended period of time. It will cause premature belt wear or may destroy the belt. **ALWAYS** set the engine speed to idle when the hand clutch is disengaged.

8. INITIAL START-UP

Before starting the operator must know the location and function of all controls.

1. Adjust the chair to the comfortable position for the operator.
2. Push down on the left safety stop pedal, turn the engine key switch, and hold it until the engine starts. (Figure 2)

NOTICE: If the engine is cold, pull out the choke control knob fully. The choke may need to be opened even when starting a warm engine



Figure 2

NOTICE: Cranking the engine for more than 5 seconds can cause starter damager. If the engine fails to start, release the key switch, and wait 10 seconds before operating the starter again.

NOTICE: Cranking the engine for more than 5 seconds can cause starter damage. If the engine fails to start, release the key switch, and wait 10 seconds before operating the starter again.

3. Allow the engine to warm up before operating the trowel
4. Push down on the throttle foot pedal to start the trowel

Cold Start-up Procedures

When ambient temperatures are below 60°F (16°C) cold weather startup procedures must be followed before bringing machine into maximum engine RPM and rotor speed. If the procedure is not followed, damage could occur which will void the warranty. (Figure 3)

See below for startup procedure.



When ambient temperatures are below 60°F (16°C) run engine at 1/4" throttle. There is an arrow (A) located on a decal showing where the throttle lever's front edge should be located. Engage the rotors by pressing on the right foot pedal for approximately 5 to 7 minutes to allow the engine system time to adequately warm up before operation.

8.2 To Stop

1. Return the control levers to their neutral position and release pressure on the throttle foot pedal.
2. Release pressure on the safety stop switch.
3. To stop the engine, turn the key switch to “O” (off).

NOTICE: Release the safety stop switch for emergency stop.



8.3 Operation

To utilize your Ride-On Trowel to its fullest capacity, the machine should be driven in the direction that the operator is facing. This will finish the widest possible area, while giving the operator an excellent view of the slab surface about to be troweled. When the machine reaches the end of the slab, make a 180°U-turn, and repeat the straight line of direction to the other end of the slab.

DO NOT use excessive pressure on the control levers. Excessive pressure does not increase the reaction time of the machine and can damage the steering controls.

NOTICE: Attempting to use the trowel too early in the curing stage of the concrete may result in an undesirable finish. Only experienced concrete finishers should operate the trowel.

8.4 Steering the ride-on trowel

A slight “feathering motion” forward and backward with the left-hand joystick is required to move the machine in a straight path to the left or right while operating the right-hand joystick.

1. Reverse: Pull the control arm reverse
2. Forward: Push the control arms forward
3. Rotate clockwise: Push the left control arm forward, pull the right control arm reverse.
4. Rotate counterclockwise: Push the right control arm forward, pull the left control arm reverse.

FIGURE 13

3.4 Transporting Trowels

Always turn the engine off and remove the key from the machine before moving or transporting machine.

To hoist the trowel:

- Attach a sling or chains through the tie-down point (a) on each side of the guard ring

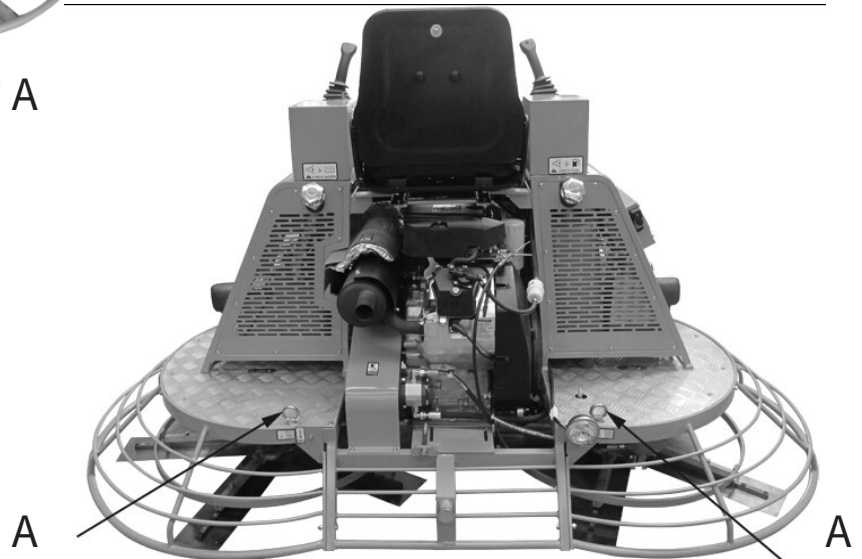
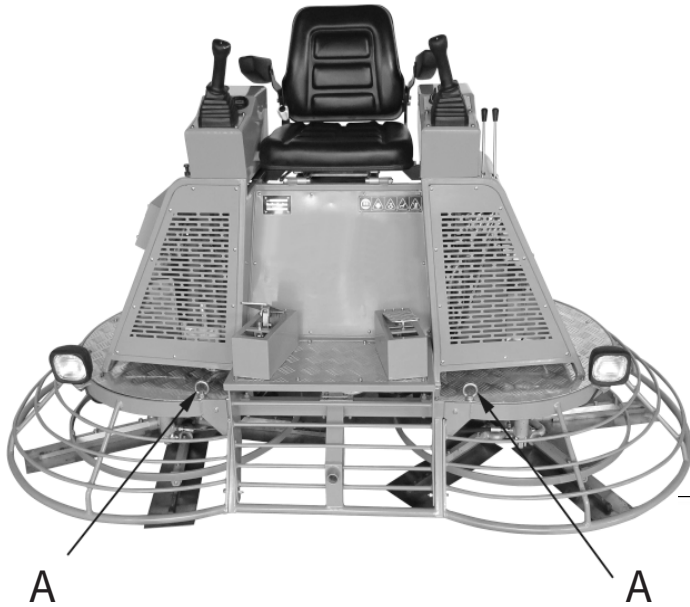

- Avoid sharp turns to prevent rolling
- At all times while towing trailer should be adjusted to a level position
- When towing wheels should be locked at all times

NOTICE: Make sure lifting device has enough capacity to hold machine (see identification plate on machine for weight).

1.

2.1 Features and Controls

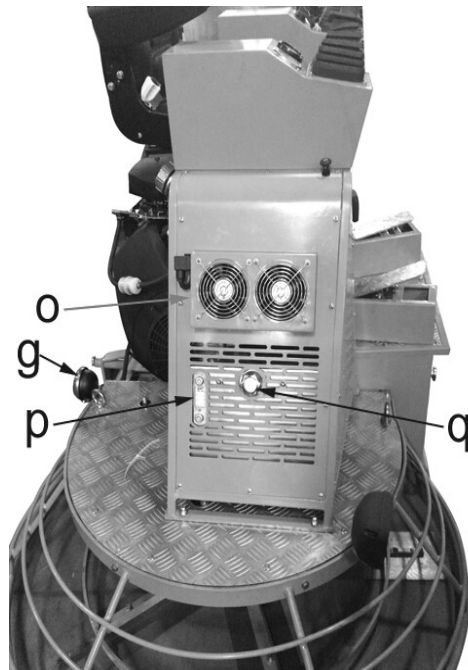
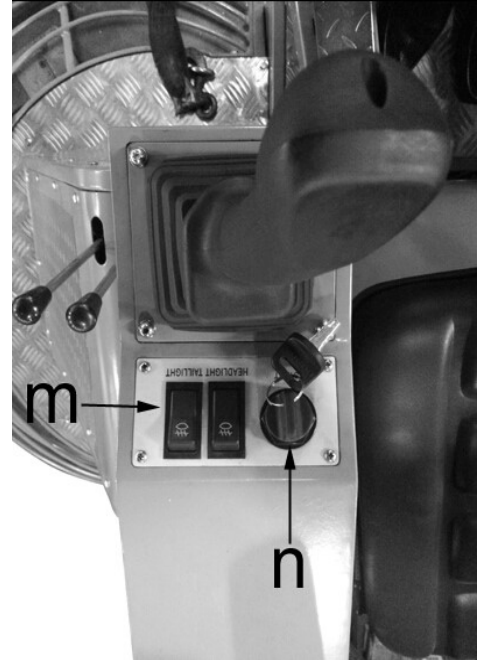
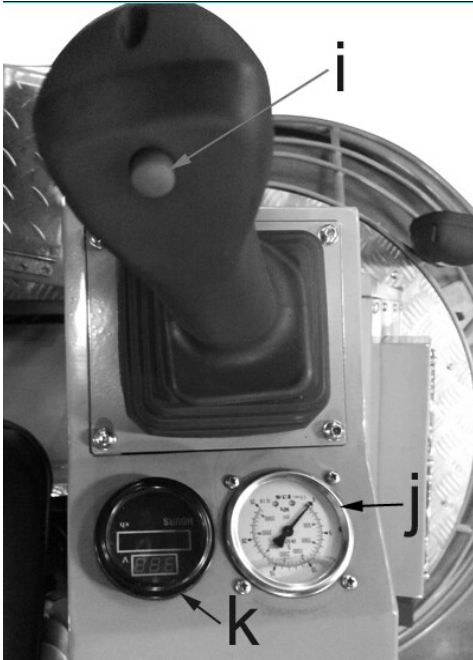

Ref. No.	Description
A.	Joystick (Forward & Reverse)
B.	Joystick (Left & Right, Forward & Reverse)
C.	Pitch Control
D.	Engine Choke Control
E.	Foot Pedal (Throttle Control)
F.	Foot Pedal (Safety Stop Switch)
G.	Work Light (3 Lights)
H.	Operator's Seat
I.	Water Spray Control
J.	Hydraulic Pressure Indicator
K.	Volt and Hour Meter
L.	Work Light Switch
M.	Engine Key Switch
N.	Hydraulic Cooling System
O.	Hydraulic Oil Level Gauge
P.	Hydraulic Oil Tank Cap
Q.	Seat Adjustment
R.	Trolley Wheel Lift Points

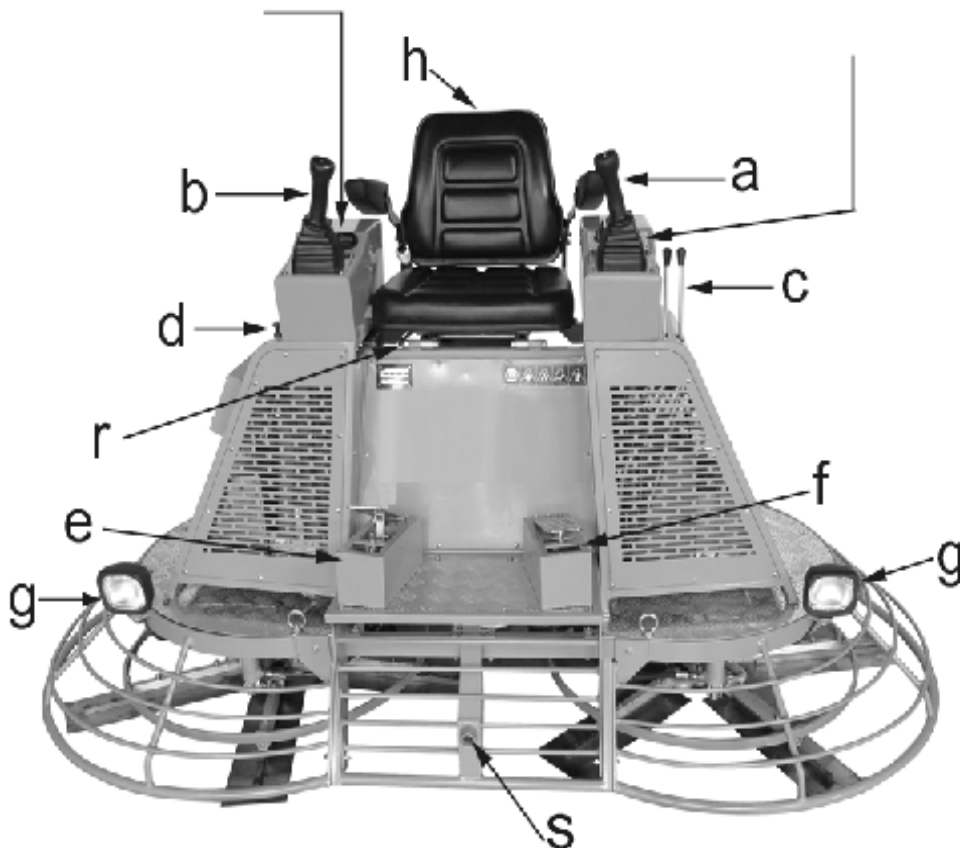

3.5 Trouble Shooting

SYMPTOM	POSSIBLE CAUSES	SOLUTION
Engine does not start	<ul style="list-style-type: none"> • Engine problem 	<ul style="list-style-type: none"> • Consult engine manufacturer's service manual
Machine out of balance; wobbling excessively	<ul style="list-style-type: none"> • Operator is over-steering • Trowel arm(s) bent • Trowel blade(s) bent • Main shaft(s) bent due to machine being dropped 	<ul style="list-style-type: none"> • The movement of each gearbox is controlled by "stops" to provide the correct relationship of the control arm movement to machine movement. Excessive pressure on control arms in any direction will not increase reaction time and can damage steering controls causing machine to wobble • Replace trowel arms(s) • Replace trowel blade(s) • Replace main shaft(s)
Machine does not move	<ul style="list-style-type: none"> • Drive belt broken • Vacuum between bottom of blades and surface of concrete • Key sheared in the main shaft 	<ul style="list-style-type: none"> • Replace drive belt • Change pitch on blades to break suction • Replace damaged key
Trowel noisy	<ul style="list-style-type: none"> • Trowel blades have become misaligned and are contacting each other during rotation • Sheared key • Loose clutch 	<ul style="list-style-type: none"> • Replace damaged blades. Align blades so that one set represents a (+) and the other an (x) when viewed from above • Check all keys in drive system • Tighten clutch

13. MAINTENANCE

13.1 Maintenance Schedule

Daily (8-10 Hours)

1. Check the oil level in the engine crankcase and gear box, fill as necessary.
2. Check V-belt.

Weekly (50-60 Hours)

1. Relube arms, thrust collar and clutch
2. Replace blades if necessary.
3. Check and clean or replace the engine air filter as necessary.
4. Replace engine oil and filter as necessary, see engine manual.

Monthly (200-300 Hours)

1. Remove, clean, reinstall and relube the arms and thrust collar. Adjust the blade arms.

Yearly (2000-2500 Hours)

1. Check and replace if necessary the arm bushings, thrust collar bushings and shaft seals.
2. Check pitch control cables for wear.
3. Adjust blade speed.

13.2 Trowel Arm Adjustment

Use the following procedure to check and adjust trowel arms, and check for worn or damaged components when it becomes apparent that the trowel is finishing poorly or in need of routine maintenance. Look for the following indications. Trowel arm alignment, worn spider bushings or bent trowel arms may be the cause.

- Are blades wearing unevenly? Is one blade completely worn out while the others look new?
- Does the machine have a perceptible rolling or bouncing motion when in use?
- Look at the machine while it is running; do the guard rings “rock up and down” relative to the ground?

13.2.1 Place the trowel in a FLAT, LEVEL area.

A level, clean area to test the trowel prior to and after is essential. Any unlevel spots in the floor or debris under the trowel blades will give an incorrect perception of adjustment. Ideally, a 5 x 5 Ft. (1.5 x 1.5 Meter) three-quarter inch (19 mm) thick FLAT steel plate should be used for testing.

13.2.2 Pitch the blades as flat as possible. The adjustment bolts should all barely make contact with the lower wear plate on the spiderbox. If one is not making contact, adjustment will be necessary. (Figure 17FIGURE 4).

13.2 Trowel Arm Adjustment Continued

Figure 17 illustrates, "incorrect alignment", worn spider bushings or bent trowel arms. Check that the adjustment bolt is barely touching (0.10" max. clearance) lower wear plate. All alignment bolts should be spaced the same distance from the lower wear plate.

- 1 Adjustment Bolt
- 2 Lower Wear Plate
- 3 Surface
- 4 "Dished" Effect on Finished Concrete

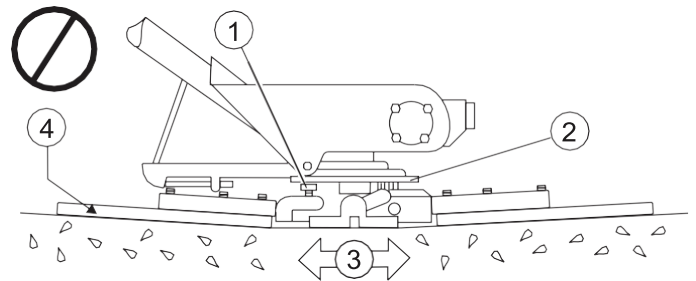

FIGURE 17

13.3 Trowel Blade Removal



WARNING:

Disconnect the spark plug wire from the spark plug and secure away from the engine before performing maintenance or adjustments on the machine.

13.3.1 Remove the trowel blades from the trowel arm by removing the two hex head bolts from the trowel arm. Set blades aside.

13.3.2 Wire brush any build-up of concrete from all six sides of the trowel arm. Repeat this for the remaining three arms.

13.4 Re-Assembly

13.4.1 Clean and examine the upper/lower wear plates and thrust the collar.

13.4.2 Examine the entire spider assembly. Wire brush any concrete or rust build-up. If any spider components are found to be damaged or misshaped, replace it.

13.4.3 Reinstall bronze bushing on the trowel arms.

13.4.4 Repeat above steps for each trowel arm.

13.4.5 Make sure that the spring tensioner is in the correct position to exert tension on the trowel arm.

13.4.6 With the bronze bushing already installed, insert all the trowel arms with levers into the spider plate.

13.4.7 Use care to align the grease hole on the bronze bushing with the grease hole fitting on the spider plate.

13.4.8 Lock the trowel arms in place by tightening the hex head bolt with zerk grease fitting and jam nut.

13.4.9 Re-install the blades onto the trowel arms.

13.4.10 Install the stabilizer ring onto the spider assembly.

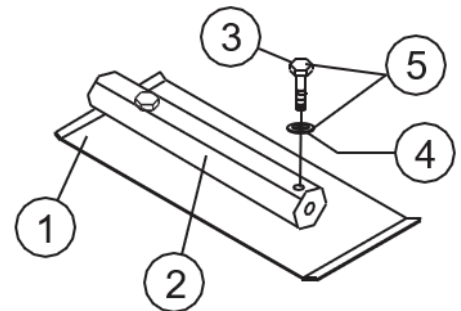

- 1 Blade
- 2 Blade Arm
- 3 Hex Head Bolt
- 4 Lock Washer
- 5 Remove from Arm

FIGURE 18

13.5 Changing Blades Only

We recommend that all of the blades are changed at the same time. The trowel may wobble or bounce if not.

13.5.1 Place the machine on a flat, level surface. Adjust the blade pitch control to make the blades as flat as possible.

NOTE

Pay attention to the blade orientation on the trowel arm.

13.6 Installing Pans onto Finisher Blades

13.6.1 Lift the trowel just enough to slide the pan under the blades. With the blades adjacent to the Z-clips, lower the finisher onto the pan.

13.6.2 Rotate the blades into position under the Z-clips. Ensure that the blades are rotated in the direction of travel when the machine is in operation. Or, use the engine to rotate the blades into position.

13.6.3 Attach the blade tie-downs to the far side of the Z-clip brackets with tie-down knobs.

13.6.4 Before the machine is put back into operation, check to make sure that the blade edges are secured under the Z-clips.

13.6.5 Before the machine is put back into operation, check to make sure that the tie-downs are secured firmly over the edges of the blade.



WARNING:

Lifting/Crush Hazard.

Do not lift the trowel with the pans attached.

ALWAYS install the pans on the work area or an area that is next to/level with the work area.

DO NOT lift the trowel when the pans are attached.

13.7 Spider Box Removal

13.7.1 Once it is determined that an adjustment is required, remove the spider assembly from the gearbox shaft as follows:

13.7.2 Remove the zerk fitting and allen head screw designated by the letter “S”.

13.7.3 On the opposite side of the spider block, there is another zerk fitting and allen head screw. Remove both of these components.

13.7.4 Lift the upper trowel assembly off of the spider assembly.

NOTE

A slight tap with a rubber mallet may be necessary to dislodge the spider from the main shaft of the gearbox.

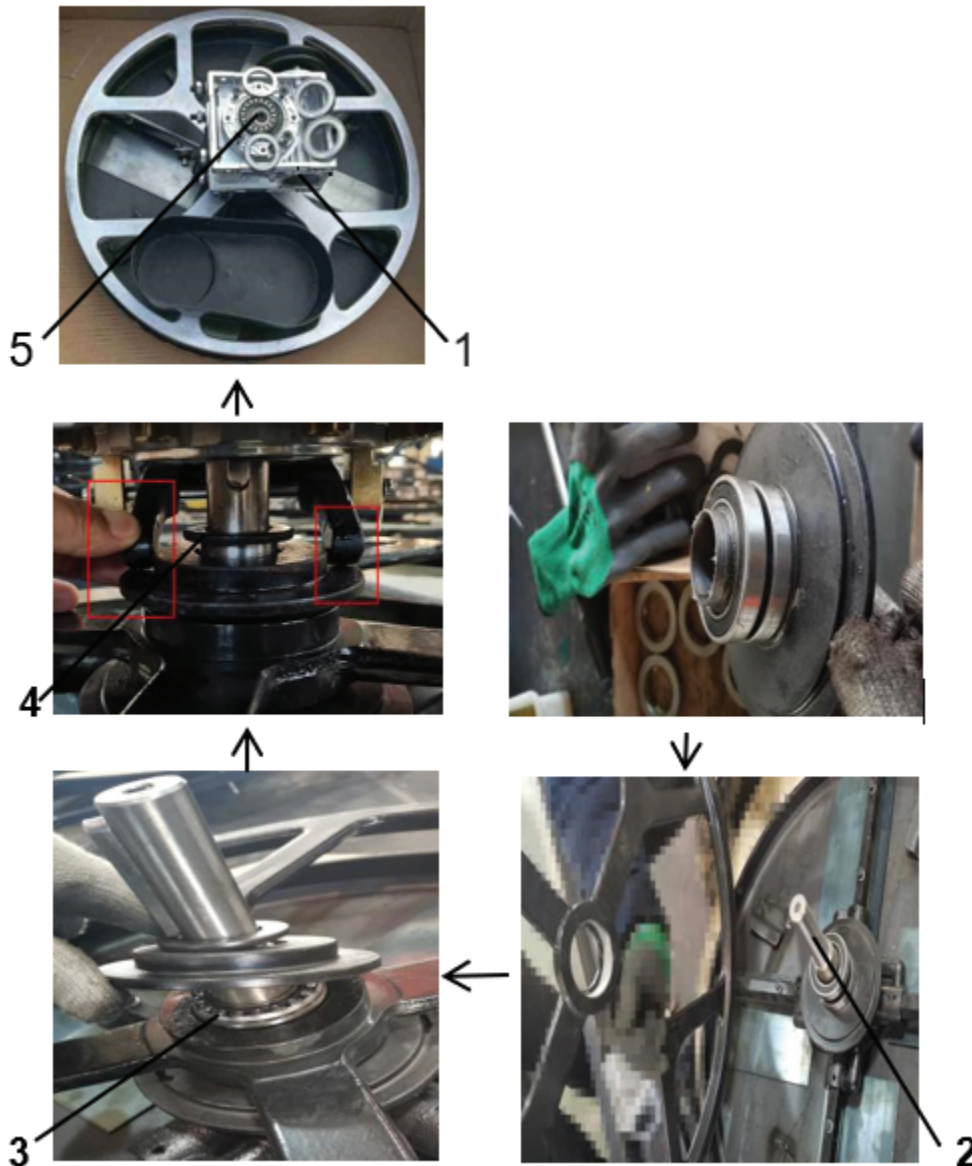

14. TRAINING CHECKLIST

This checklist lists the requirements for proper machine maintenance and operation. Please feel free to detach it and make copies. Use this checklist whenever a new operator is to be trained.

TRAINING CHECKLIST			
NO.	DESCRIPTION	COMPLETED	DATE
1	Read Operator's Manual completely		
2	Understand machine layout, location of components, check engine and gearbox fluid level		
3	Understand fuel system, refueling procedure		
4	Understand how to operate machine		
5	Understand safety controls		
6	Understand emergency stop procedures		
7	Start Up the machine		
8	Properly Maneuver the machine		
9	Understand blade bitch adjusment		
10	Understand proper proper finishing techniques		
11	Understand how to shutdown of machine		
12	Understand how to safely lift the machine		
13	Understand proper machine transport and storage		

Operator _____

Trainee _____

Comments:

PARTS MANUAL

TRT46V

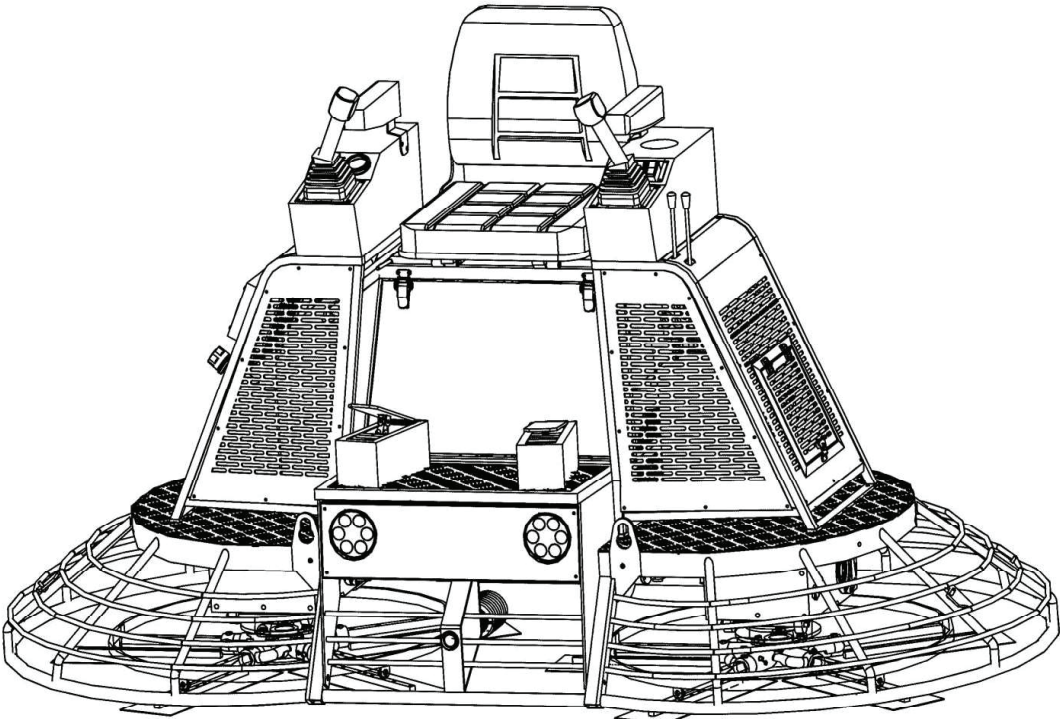

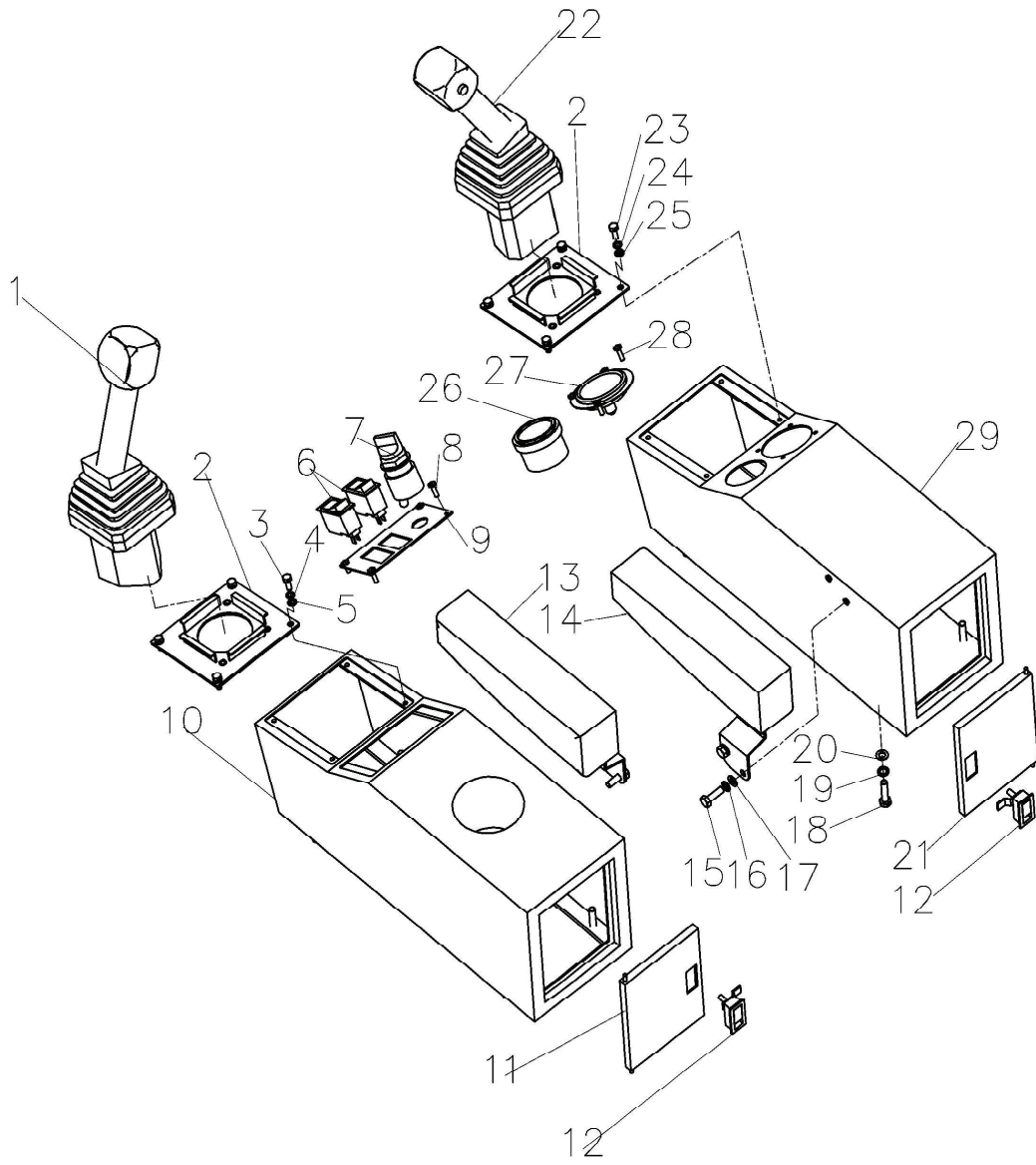

Hydraulic Ride-on Power Trowel Parts List

TRT46V

ITEM NO.	PART NO.	QTY	DESCRIPTION
1	G104601001	1	Joystick, Left
2	T104601001	2	Cover
3	00070006-16	4	Socket Head Screw, M6x16
4	00093006	4	Spring Washer
5	00095006	4	Washer
6	G104601002	2	Switch, Light
7	G104601003	1	Lock
8	00818005-10	4	Screw, M5x10
9	T104601002	1	Control Panel
10	T104601003	1	Joystick Holder, Left
11	T104601004	1	Cover, Joystic Holder, Left
12	G104601004	2	Lock
13	G104601005	1	Handle, Left
14	G104601006	1	Handle, Right
15	05783008-25	4	Hex Head Screw, M8x25
16	00093008	4	Spring Washer
17	00095008	4	Washer
18	05783008-35	8	Hex Head Screw, M8x35
19	00093008	8	Spring Washer
20	00095008	8	Washer
21	T104601005	1	Cover, Joystic Holder, Right
22	G104601007	1	Joystick, Right
23	05783006-16	4	Hex Head Screw, M6x16
24	00093006	4	Spring Washer
25	00095006	4	Washer
26	G104601008	1	Volt and Hour Meter
27	G104601009	1	Hydraulic Pressure Indicator
28	00818005-10	3	Screw, M5x10
29	T104601006	1	Joystick Holder, Right

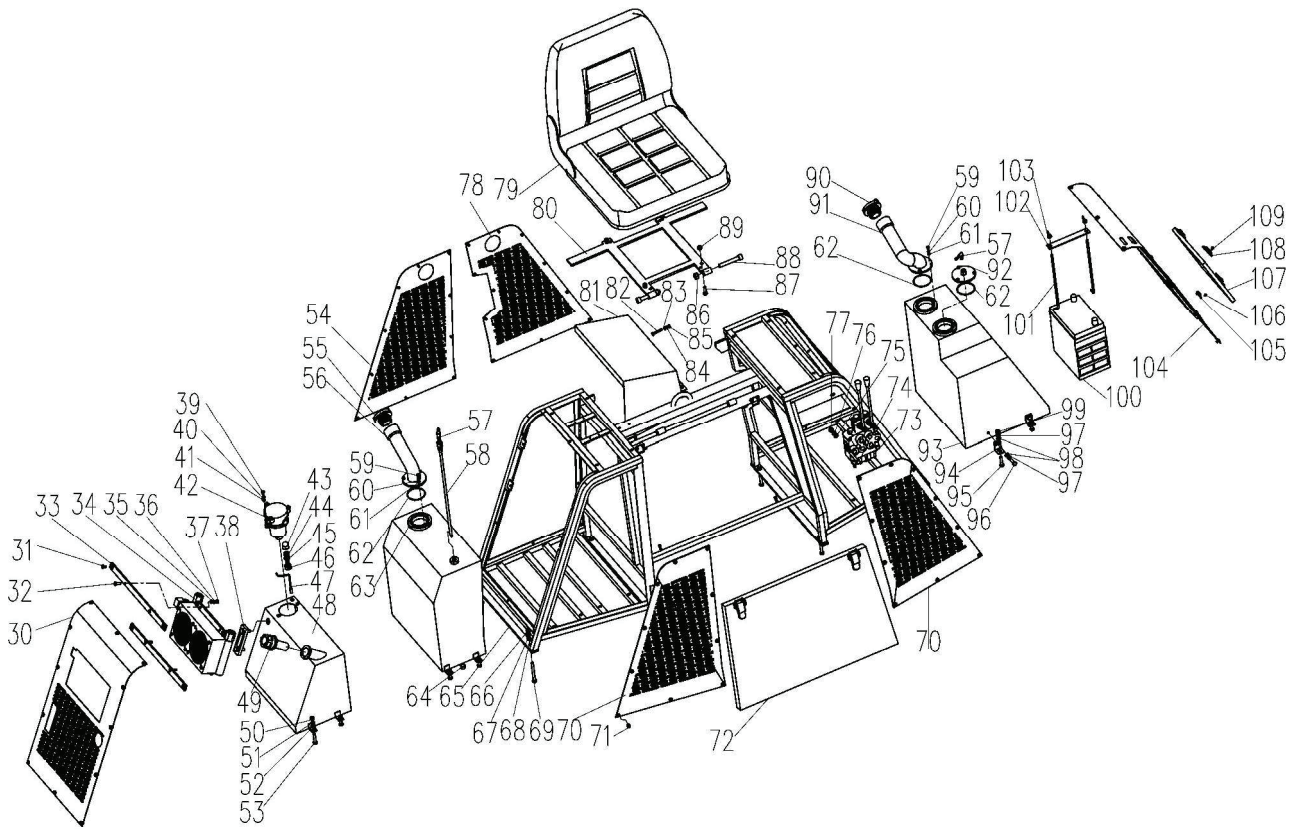

Hydraulic Ride-on Power Trowel Parts List

TRT 46V

ITEM NO.	PART NO.	QTY	DESCRIPTION
30	T104602001	1	Protective Plate, Right
31	00070006-12	4	Socket Head Screw, M6x12
32	00818006-20	4	Screw, M6x20
33	T104602002	2	Connecting Plate
34	G104602002	1	Cooling System
35	00095006	4	Washer
36	00093006	4	Spring Washer
37	06170006	4	Hex Nut, M6
38	G104602003	1	Hydraulic Oil Level Gauge
39	05783006-16	2	Hex Head Screw, M6x16
40	00093006	2	Spring Washer
41	00095006	2	Washer
42	G104602004	1	Filter
43	00923012	1	Nut, M12
44	00093012	1	Spring Washer
45	G104602005	1	Washer
46	G104602006	1	Hex Head Srew
47	G104602007	1	Tempreture Sensor
48	T104602003	1	Hydraulic Oil Tank
49	G104602008	1	Fuel Filter
50	06170008	8	Hex Nut, M8
51	00095008	8	Spring Washer
52	00093008	8	Washer
53	05783008-35	8	Hex Head Screw, M8x35
54	T104602004	1	Plate, Seat
55	G104602009	1	Oil Tank Cover
56	G104602010	1	Oil Pipe
57	G104602011	1	Lever, Oil Tank
58	G104602012	1	Oil Pipe
59	00818005-20	9	Screw, M5x20
60	00093005	9	Spring Washer
61	00095005	9	Washer
62	03452063	3	Oil Seal
63	T104602005	1	Oil Tank
64	00444018	1	Oil Plug
65	T104602006	1	Frame
66	00923008	8	Nut, M8
67	00093008	8	Spring Washer
68	00095008	8	Washer
69	05783008-90	8	Hex Head Screw, M8x90

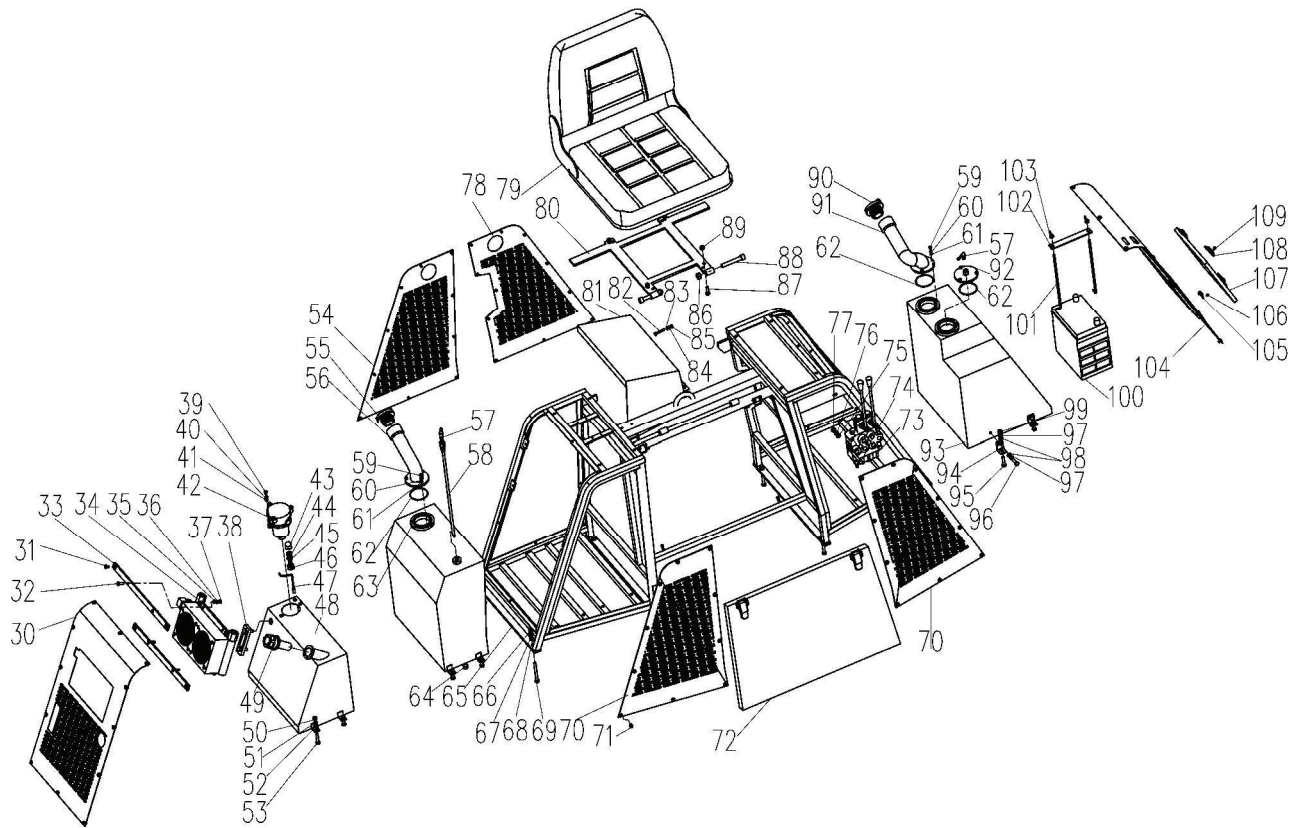

Hydraulic Ride-on Power Trowel Parts List

TRT 46V

ITEM NO.	PART NO.	QTY	DESCRIPTION
70	T104602006	2	Plate, Seat
71	00818005-10	64	Screw, M5x10
72	T104602007	1	Plate
73	G104602013	1	Valve
74	05783008-55	3	Hex Head Screw, M8x55
75	00095008	3	Washer
76	00093008	3	Spring Washer
77	06170008	3	Hex Nut, M8
78	T104602008	1	Plate, Seat
79	G104602014	1	Seat
80	T104602009	1	Hinge
81	T104602010	1	Proctive Frame, Engine
82	05783006-35	3	Hex Head Screw, M6x35
83	00095006	3	Washer
84	00093006	3	Spring Washer
85	06170006	3	Hex Nut, M6
86	00889012	2	Lock Nut, M12
87	05783008-25	4	Hex Head Screw, M8x25
88	00070012-75	2	Socket Head Screw, M12x75
89	00889008	4	Lock Nut, M8
90	G104602015	1	Cover, Water Tank
91	G104602016	1	Water Hose
92	G104602017	1	Gasket, Water Tank
93	T104602011	1	Water Tank
94	T104602012	4	Fixed Connector
95	05783008-40	4	Hex Head Screw, M8x40
96	05783008-20	4	Hex Head Screw, M8x20
97	00093008	8	Spring Washer
98	00095008	8	Washer
99	06170008	4	Hex Nut, M8
100	G104602018	1	Battery
101	G104602019	2	Screw
102	G104602020	1	Fixed Plate
103	00062006	2	Nut, M6
104	T104602013	1	Proctive Plate
105	G104602021	1	Lock Nut
106	00818004-10	4	Screw, M4x10
107	T104602014	1	Cover
108	G104602022	2	Hinge
109	00819005-16	8	Screw, M5x16

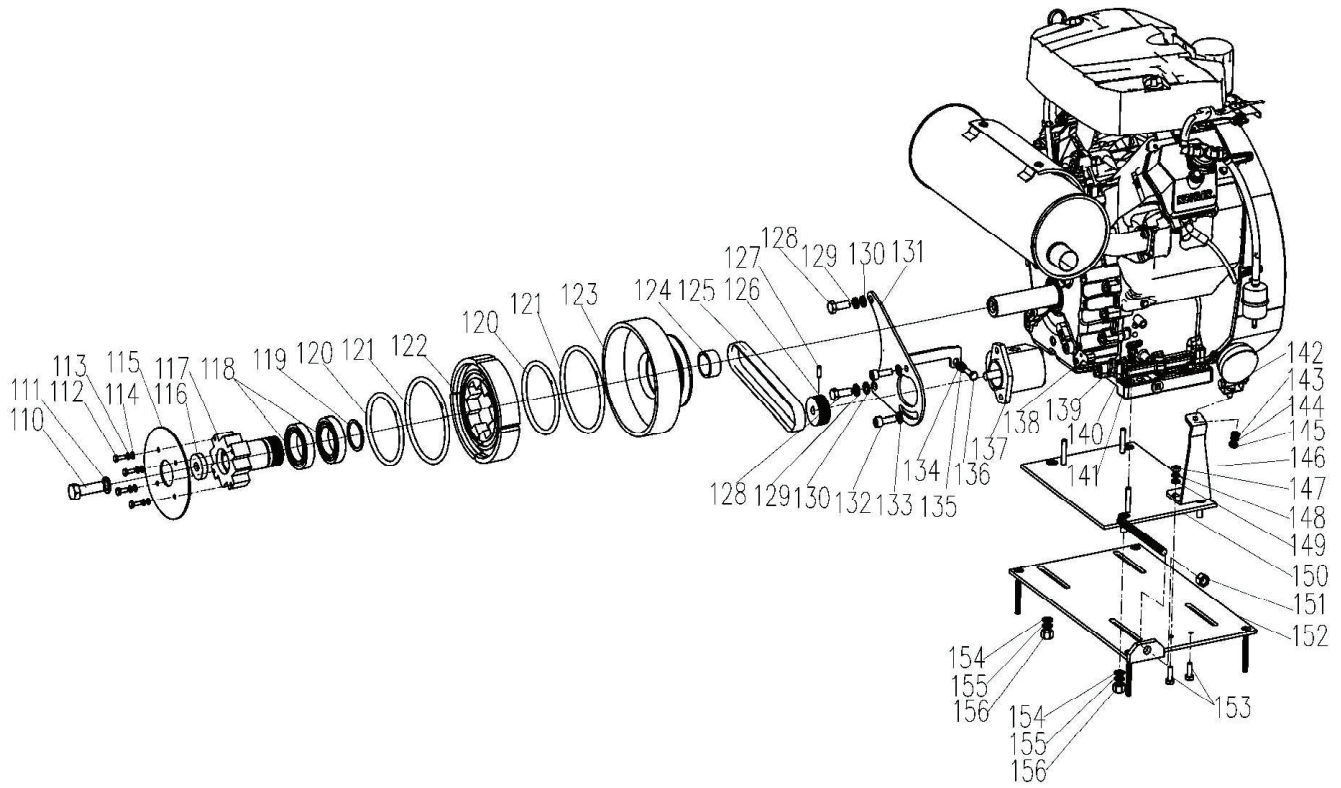

ITEM NO.	PART NO.	QTY	DESCRIPTION
110	G104603001	1	Hex Head Screw
111	00093016	1	Spring Washer
112	05783006-16	4	Hex Head Screw, M6x16
113	00093006	4	Spring Washer
114	00095006	4	Washer
115	T104603001	1	Cover
116	T104603002	1	Retaining Ring
117	T104603003	1	Bearing Cover
118	02766010	2	Bearing
119	00894050	1	Retaining Ring
120	G104603002	2	Spring
121	G104603003	2	Spring
123	T104603004	1	Bearing Holder
124	T104603005	1	Retaining Ring
125	G104603004	1	Belt
126	T104603006	1	Pulley
127	00077	1	Socket Head Screw
128	G104603005	2	Hex Head Screw
129	00093012	2	Spring Washer
130	00095012	2	Washer
131	T104603007	1	Connecting Plate
132	00070010-30	2	Socket Head Screw, M10x30
133	00093010	2	Spring Washer
134	00095008	1	Washer
135	00093008	1	Spring Washer
136	05783008-25	1	Hex Head Screw, M8x25
137	G104603006	1	Pump
138	G104603007	1	Engine, Kohler CH940
139	06170008	4	Hex Nut, M8
140	00093008	4	Spring Washer

Hydraulic Ride-on Power Trowel Parts List**T RT46V**

ITEM NO.	PART NO.	QTY	DESCRIPTION
141	00095008	4	Washer
142	G104603008	1	Light, Back
143	00095008	1	Washer
144	00093008	1	Spring Washer
145	06170008	1	Hex Nut, M8
146	G104603009	1	Bracket
147	06170008	1	Hex Nut, M8
148	00093008	1	Spring Washer
149	00095008	1	Washer
150	T104603008	1	Engine Mounted Plate
151	06170012	1	Hex Nut, M12
152	T104603009	1	Engine Mounted Plate
153	05783008-30	2	Hex Head Screw, M8x30
154	00095010	4	Washer
155	00093010	4	Spring Washer
156	06170010	4	Hex Nut, M10

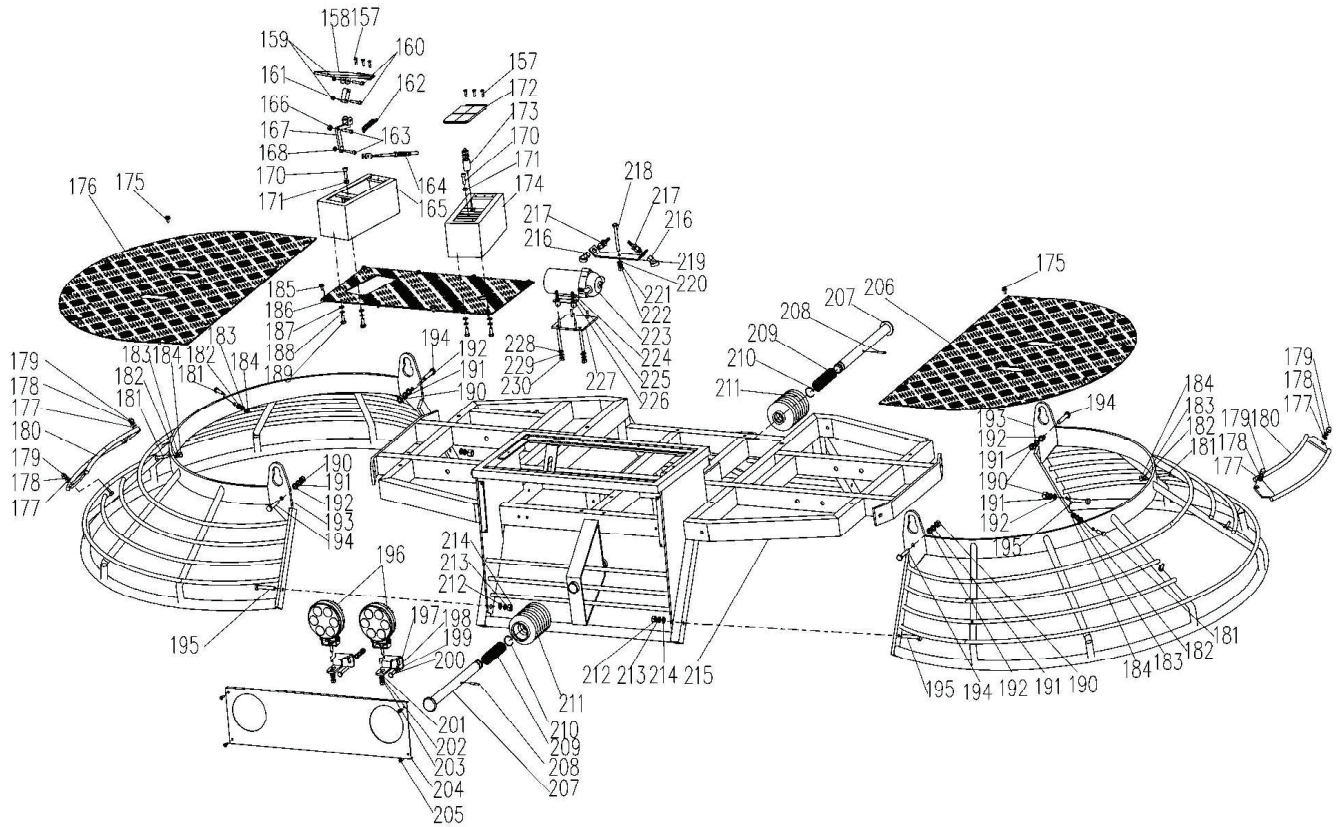

Hydraulic Ride-on Power Trowel Parts List**T RT46V**

ITEM NO.	PART NO.	QTY	DESCRIPTION
157	00818005-25	6	Screw, M5x25
158	T104604001	1	Foot Pedal (Throttle Control)
159	00889006	2	Lock Nut, M6
160	00070008-25	2	Socket Head Screw, M8x25
161	T104604002	1	Plate
162	T104604003	1	Spring
163	00070008-25	2	Socket Head Screw, M8x25
164	T104604004	1	Throttle Control
165	T104604005	1	Foot Pedal
166	00889006	1	Lock Nut, M6
167	T104604006	1	Hook
168	00889006	1	Lock Nut, M6
170	00070008-25	1	Socket Head Screw, M8x25
171	06170008	1	Hex Nut, M8
172	T104604007	1	Safety Stop Switch
173	G104604001	1	Engine Stop Switch
174	T104604008	1	Foot Pedal
175	05789006-12	12	Hex Screw, M6x12
176	T104604009	1	Proctive Plate, Right
177	00095008	4	Washer
178	00093008	4	Spring Washer
179	00923008	4	Nut, M8
180	G104604002	2	Cover
181	05783010-35	4	Hex Head Screw, M10x35
182	00095010	4	Washer
183	00093010	4	Spring Washer
184	06170010	4	Hex Nut, M10
185	05789006-12	10	Hex Screw, M6x12
186	T104604009	1	Proctive Plate, Front
187	00095008	8	Washer
188	00093008	8	Spring Washer
189	05783008-20	8	Hex Head Screw, M8x20
190	06170010	4	Hex Nut, M10
191	00093010	4	Spring Washer
192	00095010	4	Washer
193	T104604010	2	Guard Ring

ITEM NO.	PART NO.	QTY	DESCRIPTION
194	05783010-55	4	Hex Head Screw, M10x55
195	05783010-55	4	Hex Head Screw, M10x55
196	G104604003	2	Light
197	T104604011	2	Bracket
198	00095008	4	Washer
199	00093008	4	Spring Washer
200	05783008-20	4	Hex Head Screw, M8x20
201	00095008	2	Washer
202	00093008	2	Spring Washer
203	06170008	2	Hex Nut, M8
204	T104604012	1	Logo Plate
205	00818006-16	4	Screw, M6x16
206	T104604013	1	Cover, Left
207	T104604014	2	Shaft
208	00879005-30	2	Pin
209	G104604004	2	Spring
210	00894027	2	Retaining Ring
211	T104604015	2	Rubber Cover
212	06170010	4	Hex Nut, M10
213	00093010	4	Spring Washer
214	00095010	4	Washer
215	T104604016	1	Frame
216	G104604005	2	Spray Nozzle
217	G104604006	2	Connector
218	05783008-80	1	Hex Head Screw, M8x80
219	T104604017	1	Connector Plate
220	00095008	1	Washer
221	00093008	1	Spring Washer
222	06170008	1	Hex Nut, M8
223	G104604007	1	Pump
224	06170005	4	Hex Nut, M5
225	00093005	4	Spring Washer
226	00095005	4	Washer
227	T104604018	1	Connector
228	00095008	2	Washer
229	00093008	2	Spring Washer
230	06170008	2	Hex Nut, M8

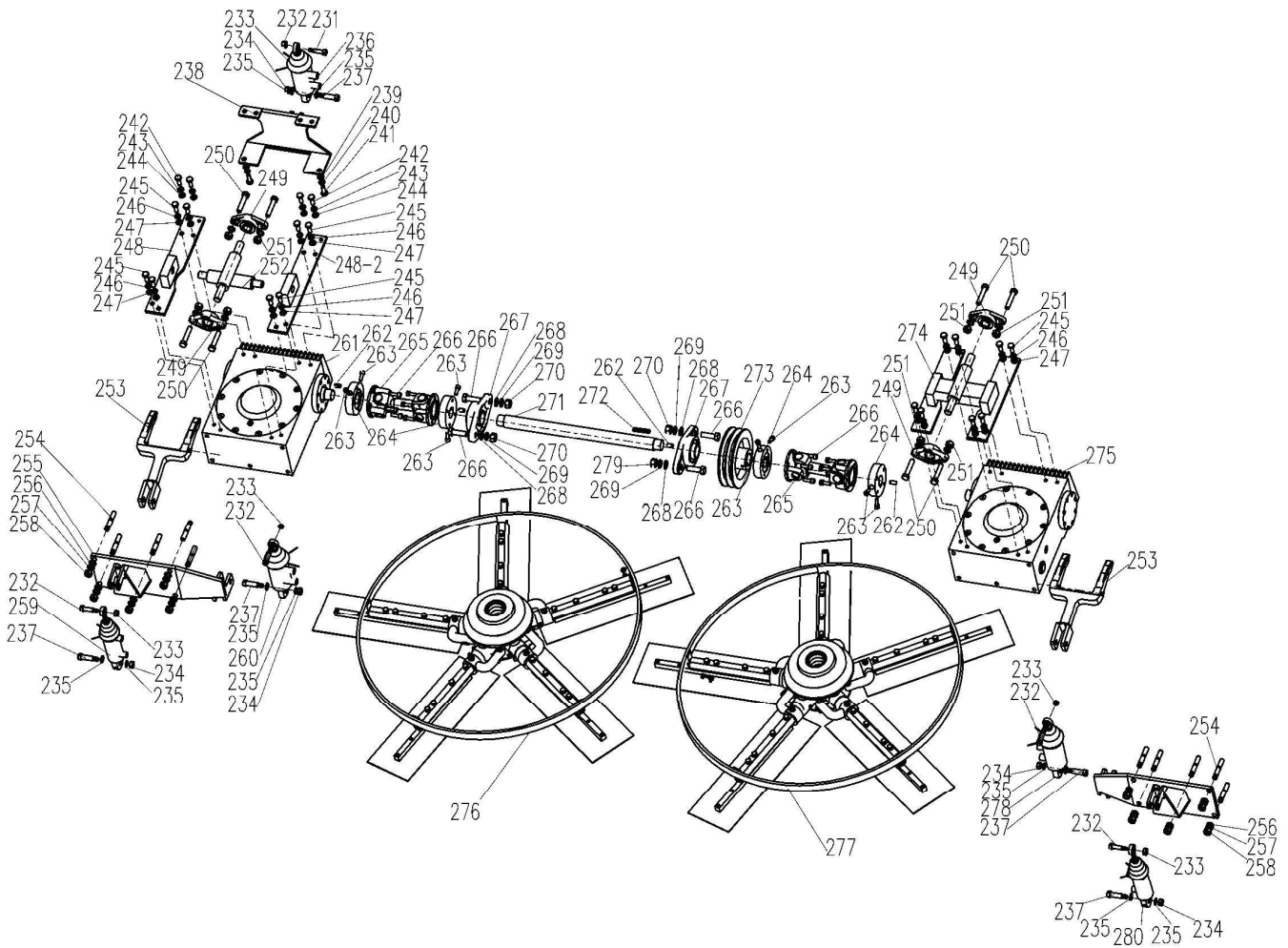

ITEM NO.	PART NO.	QTY	DESCRIPTION
231	T104605001	5	Screw
232	00889008	5	Lock Nut, M8
233	T104605002	5	Rubber Cover
234	00889010	5	Lock Nut, M10
235	00095010	10	Washer
236	G104605001	1	Cylinder
237	T104605003	5	Screw
238	T104605004	1	Bracket
239	00095010	2	Washer
240	00093010	2	Spring Washer
241	05783010-25	2	Hex Head Screw, M10x25
242	05783010-25	4	Hex Head Screw, M10x25
243	00093010	4	Washer
244	00095010	4	Spring Washer
245	05783012-30	8	Hex Head Screw, M12x30
246	00093012	8	Washer
247	00095012	8	Spring Washer
248	T104605005	1	Base Plate, Right
248-2	T104605006	1	Base Plate, Left
249	G104605002	4	Bearing Holder
250	05783012-65	8	Hex Head Screw, M12x65
251	00889012	8	Lock Nut, M12
252	G104605003	2	Shaft
253	T104605007	2	Yoke
254	00901012-60	10	Screw, M12x60
255	T104605008	1	Plate, Right
256	00095012	10	Washer
257	00093012	10	Spring Washer
258	06170012	10	Hex Nut, M12
259	G104605004	1	Cylinder
260	G104605005	1	Cylinder
261	T104605009	1	Gearbox Assy., Right
262	01096008-20	4	Key
263	00070008-20	8	Socket Head Screw, M8x20
264	T104605010	4	Flange



Power Your World

Tomahawk understands to keep a job-site running smoothly the proper equipment and spare parts are needed at the drop of a hat. With same day shipping and faster delivery times, count on Tomahawk to keep you powered throughout the day! With long lasting parts and engines, Tomahawk equipment will be the star of your fleet for years to come. Visit www.tomahawk-power.com to get started today!

Tomahawk Power, LLC
San Diego, CA

Sales Support
(866) 577-4476
sales@tomahawk-power.com

Equipment Support
(866) 577-4476
support@tomahawk-power.com

www.tomahawk-power.com



FACEBOOK
facebook.com/TomahawkPowerUSA

YOUTUBE
youtube.com/TomahawkPower

INSTAGRAM
[@tomahawkpower](https://instagram.com/tomahawkpower)